

**CODE 06 - DEPT. V - SECTION 1
OUT OF FIELD TRACTOR PULLING RULES**

Contact: Mark Wilmot – (518) 752-8330

A weight and distance contest.

Wednesday at 10:00 A.M.

OUT OF FIELD

FIELD STOCK FARM TRACTORS NOT EXCEEDING MANUFACTURERS ENGINE

**All Classes will be sweepstaked - \$15.00 Entry Fee Per Class
Membership is optional (\$15.00)**

Classes

- | | | |
|---|-----------------------------|---------------------------------------|
| 1. Under 4,500 lbs. | 5. Under 8,000 lbs. | 9. Under 15,500 lbs. |
| 2. Under 5,500 lbs. | 6. Under 9,500 lbs. | 10. Under 10,500 lbs. Enhanced |
| 3. Under 6,500 lbs. | 7. Under 11,500 lbs. | 11. Under 11,500 lbs. Enhanced |
| 4. Antique-Under 7,500 lbs.
& Under-Completely Stock (1960 or Older) | 8. Under 13,500 lbs. | |

Classes 1-5-Naturally Aspirated Only (No Turbo)

Classes 6 - 10 *With or without Turbo

Classes 1-6 - 5 M.P.H. Speed Limit

Classes 7-9 - 8 M.P.H. Speed Limit

Classes 10-11 - No Speed Limit or RPM Limit

Rules and Regulations

1. Pull will be open to anyone 18 years of age or older. **Do we need to modify this rule??**
2. Tractors must be commercially manufactured rubber-tired 2-wheel drive type; no tire chains or dual rear wheels. Overall length of tractor shall not be altered from manufacturer's standard specifications and no visual engine modifications on stock tractors.
3. Minimum drawbar length 18 inches from center of rear wheels to point of hook. Drawbar to be stationary in all directions. Maximum height of 20 inches from top of hitching device parallel to ground.
4. Drawbar must be equipped with a steel hitching device not more than 1-1/2 inch thickness, and with a 3 inch diameter opening. Cross-sectional thickness must be 7/8-inch minimum. Pulling point may not be more than 1-1/2 inches from back edge of hitching device. Clevis will be allowed.
5. No pulling from 3-point hitch arms allowed. Quick hitch drawbar must be operated from a fixed position.
6. No pressurized fuels allowed except in UL (Underwriters Laboratories) approved pressure tanks. No oxygen allowed.
7. Judge has final decision to disqualify.

Safety and Tractor Operation

1. All tractors must be operated in a safe manner at all times.
2. Operator must remain seated during the pull, and must have complete control of the tractor at all times.
3. All tractor seats must pass a safety inspection.
4. Consumption of alcoholic beverages prior to pulling will mean disqualification. No alcoholic beverages allowed on the fairgrounds.
5. Tractors must be stopped immediately upon signal from the judge. The pull shall be considered over when forward motion of the load stops.
6. All tractors must in neutral or park (transmission selector) when being hitched or unhitched.
7. No portion of tractor may interfere with sled or sled hitch during the pull.
8. All weights must be safely secured to the tractor. Any abblast or external parts lost while hooked to the sled will be cause for disqualification including drawbar and hitches. (Internal parts excepted) Weights must not extend beyond back of rear tires. Weight brackets must be sturdy and capable of safely holding the weight attached to them. No Junk!
9. All tractors must be equipped with workable rear wheel brakes.
10. All tractors must have stock or sufficient add on fan shroud or electric operated cooling fan.
11. All tractors must be equipped with a working deadman throttle.
12. Any tractor discharging fluid on the track may be disqualified.
13. All tractors **MUST BE EQUIPPED** with a wheelie bars.

Operation of Contest

1. Each tractor may be entered in more than one class, but only once in each class.
2. Class winner may enter next class in same division (stock, altered, enhanced) by paying entry fee.
3. No mixing of classes. 2 wheel drive type; (except 4wd class) no tire chains.

Montgomery County Agricultural Society

4. Number one puller will be test puller and may take pull if weight machine is OK or he may pull in 3rd position. If weight machine needs further adjustment, first puller after each adjustment will be treated as number one puller. All decisions on re-pulls must be made before tractor in question is unhooked from sled. On any repull caused by a contest malfunction, puller at his discretion may drop back 3 positions. Any disqualification on first attempt bars a second attempt.
5. Contestant must pull at position drawn within 3 minutes of time sled is in readiness; any delay will mean disqualification. If presiding judge is notified before preceding contestant makes his pull, he may drop a contestant having mechanical problems 3 positions. This may be done only once per contestant per class.
6. All pulls must start with a tight hitch, no jerking permitted. Contestants will be allowed two attempt and 75 feet to start the sled.
7. Tractor must remain within boundaries of contest course during the pull or will be disqualified.
8. All tractors **MUST BE EQUIPPED** with wheelie bars. Must be made of min. 3/8" material, bottom of pad to track must be 10" max. rear of wheelie bars to be even with back of rear tires. No Junk! Tractors with inadequate wheelie bars will not be allowed to pull.
9. Tractors competing in the stock classes are to be FARM STOCK. A track judge will disqualify any tractor that exceeds the judge's performance standard for stock tractors. The sled operator will apply the sled brakes upon black flag signal from the flagman. Any tractor disqualified will not compete for the remainder of the day.

**NON-STOCK TRACTOR RULES (Altered Farm and Enhanced)
(Must follow all other rules plus these additional rules)**

1. Non-Stock Farm Tractors are stock appearing tractors with enhancements to create more horsepower and pulling ability than similar stock models.
2. Tractors with engine modifications, tire modifications, or higher than rated engine RPM will be expected to enter in Non-Stock Tractor classes. Tractors with above modifications entering stock classes will be disqualified and not allowed to re-enter enhanced classes.
3. A tractor must pull in either stock, altered farm or enhanced classes, no mixing of classes.
4. Cut tires will be allowed in enhanced classes only.
5. All non-stock tractors are limited to one (1) turbocharger. In altered farm classes, turbocharger is limited to a measurement of 3.0 inches measured at the face of the wheel inlet and at the outlet. Enhanced tractors have no maximum turbo dimensions. All exhaust must exit through the turbo.
6. All non-stock tractors must have adequate clutch blankets and removable engine side shields. Blankets must be secured in front with 2 straps on each side. Blankets must be as specified in the latest NTPA OR ATPA rulebook for super stock tractors.
7. All non-stock tractors must have air shutoff (diesel) or ignition shutoff (gasoline) that has a hookup ring at the rear of the tractor to be connected to transfer sled. Kill switch must be within 6" of center and not more than 48" above hitch.
8. All turbo charged tractors must have 2 - 3/8" bolts installed criss-cross through the exhaust after the turbocharger.
9. Decision of the judge(s) will be final.
10. Any tractor operated in a reckless manner or having an unsafe appearance will be disqualified. Any disqualification bars a second attempt in the class.
11. All operators must wear an approved racing helmet. It is recommended that all tractors be equipped with lapbelt, and is recommended to be worn.
12. All non-stock tractors must have a 2-1/2 lb. Dry chemical fire extinguisher mounted within easy reach of the driver.
13. Naturally aspirated tractors may have non-stock intake and exhaust manifold. Turbo charged tractors must have stock intake and exhaust manifolds.
14. All diesel tractors in altered farm classes must have stock appearing injection pumps.
15. It is highly recommended that all altered farm tractors have an SFI approved clutch and flywheel.
16. All enhanced tractors must have either a factory ROPS for the make and model tractor being pulled or a competition quality roll cage meeting the specifications set forth by the NTPA or ATPA in their most current rule book.
17. Enhanced Tractors are required to have an SFI approved clutch and flywheel. Certification papers must be available upon request; or winnings may be forfeited.

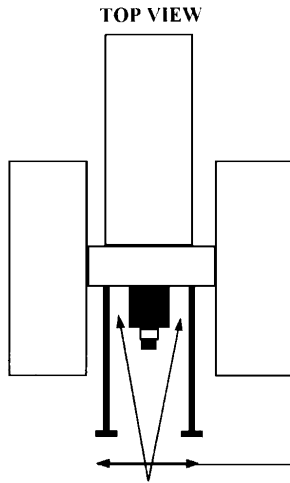

THE STABELIZER BARS AND THEIR ASSEMBLY
ARE NOT IN ANY WAY TO BE CONNECTED TO
THE DRAWBAR AND IT'S ASSEMBLY

MINIMUM OF 20 INCHES
FROM OUTSIDE OF ONE
PAD TO ANOTHER
Fig. E

FIGURE A

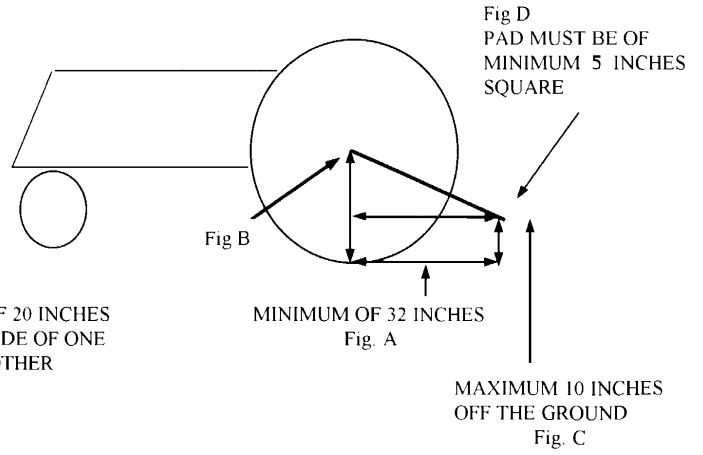

STABILIZER BAR

